

# JUXTA F Series General Specification

Model FX1□-MA (Variable software type)  
FX2□-MA (Fixed software type)  
Moving Average Unit

JUXTA

## 1. GENERAL

This is a variable or fixed software type computing unit which accepts a voltage signal from various converters and outputs the moving average computed result using the moving average time set by a handy terminal or variable resistor as an isolated DC voltage or current signal.

## 2. SPECIFICATIONS

Model No.	FX1A-MA, FX1V-MA	FX2A-MA, FX2V-MA
Input signal	DC voltage signal: 1 point	DC voltage signal: 1 point Volume setting
Measuring range	0 to 10 V DC (Measuring span: More than 2 V) (*1)	
Input resistance	1 MΩ (At power failure: More than 100 KΩ)	
Output signal	4 to 20 mA, 2 to 10 mA, 1 to 5 mA, 0 to 20 mA, 0 to 16 mA, 0 to 10 mA or 0 to 1 mA DC 0 to 10 mV, 0 to 100 mV, 0 to 1 V, 0 to 10 V, 0 to 5 v, 1 to 5 V or -10 to +10 V DC	
Moving average time setting range	0 to 7990 sec. (0.0 to 799.0%) (*2)	0 to 1000 sec. (0 to 1.000 V)
Time constant setting range	0.0 to 799.0 sec (0.0 to 799.0%) (*3)	
Basic accuracy	±0.1% of measuring span	±0.2% of measuring span
Signal insulation	Between input signal and output signal/power supply circuits, and between output signal and power supply circuits	
Insulation resistance	Between input signal and output signal/power supply circuits, between output signal and power supply circuits: 100 MΩ/500 V DC	
Dielectric strength	Between input signal and output signal/power supply circuits: 1500 V AC/min Between output signal and power supply circuits: 500 V AC/min	
Power supply voltage	24 V DC ±10%	
Ambient temperature/humidity	0 to 50°C (32 to 122°F) and 5 to 93% relative humidity (No condensation)	
Effect of ambient temperature	±0.2% of span for 10°C (50°F) change	
Effect of power supply voltage	±0.1% of span for 24 V DC ±10% variation	±0.2% of span for 24 V DC ±10% variation
Power consumption	24 V DC, 60 mA (Voltage output) and 24 V DC, 82 mA (Current output)	
Dimensions	72 (2.83") H × 24 (0.94") W × 127 (5.00") D mm (inch)	
Weight	Approx. 130 g	
Accessories	Tag number label : 1 sheet Mounting blocks: 2 pcs.	

Specify the following when ordering:

(\*1) Measuring range from □ to □mV

(\*2) Moving average time; □sec.

(\*3) 1st-order lag time constant; □sec.

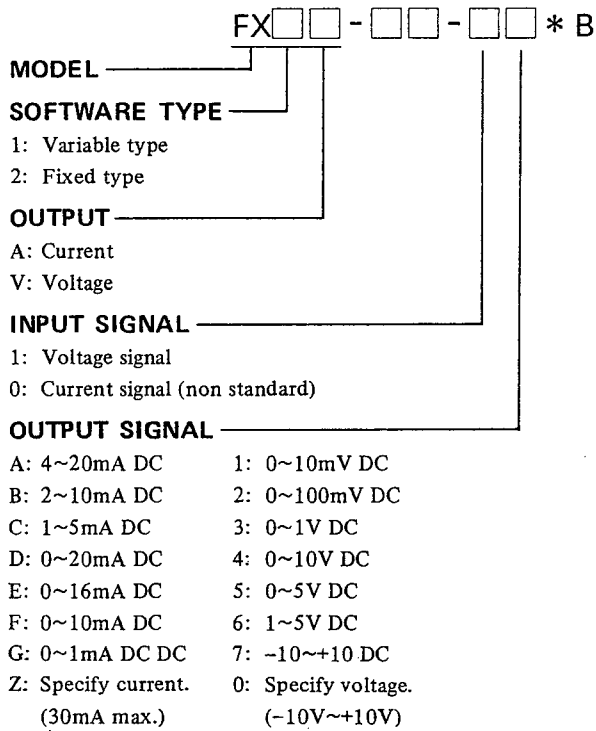

### Ordering Information

Measuring Range of Input	
Voltage input signal: 2V min. Span for 0~10V DC	
Current input signal (input resist. 250Ω): (250Ω) × (Input current) shall be within the measuring span of voltage input signal.	
	Recommended Range
Current signal	4~20mA DC 2~10mA DC 0~20mA DC 0~16mA DC 0~10mA DC
Voltage signal	0~10V DC 0~ 5V DC 1~ 5V DC

(Note) Change of input between voltage and current is impossible by Handy Terminal.

### OUTPUT RESISTANCE AND LOAD RESISTANCE

Output Signal	Load Resistance	Output Impedance
4 to 20mA DC	0 to 750Ω	5MΩ or more
2 to 10mA DC	0 to 1500Ω	
1 to 5mA DC	0 to 3000Ω	
0 to 20mA DC	0 to 750Ω	
0 to 16mA DC	0 to 900Ω	
0 to 10mA DC	0 to 1500Ω	
0 to 1mA DC	0 to 15kΩ	

Output Signal	Load Resistance	Output Impedance
0 to 10mV DC	100kΩ or more	100Ω or less
0 to 100mV DC		
0 to 1V DC	2kΩ or more	1Ω or less
0 to 5V DC		
1 to 5V DC		
0 to 10V DC	10kΩ or more	
-10 to +10V DC		

Subject to change without notice for grade up quality and performance